

# 3-WAY VALVE W/ PTFE PLUGS

---

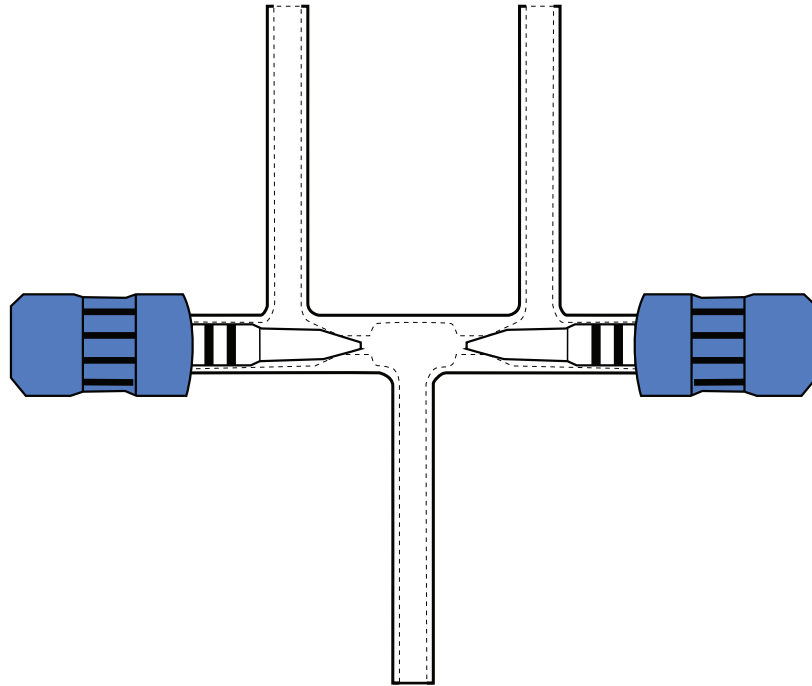

# STOPCOCK, T - BORE WITH SOLID PTFE / TEFLON PLUG

---

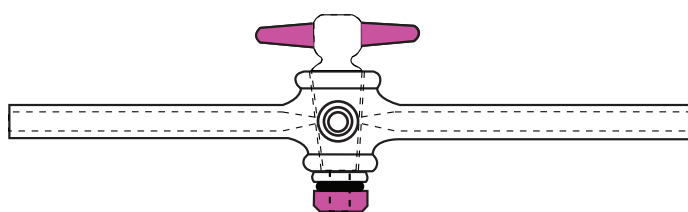

**SIDE VIEW**

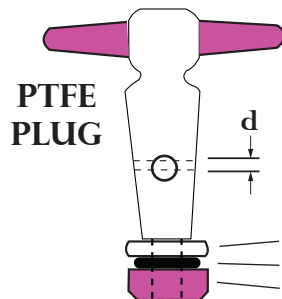

d = Stopcock plug bore (milimeters)  
= Stopcock Size

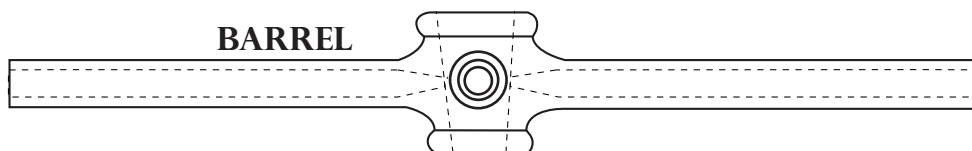

**TOP VIEW**

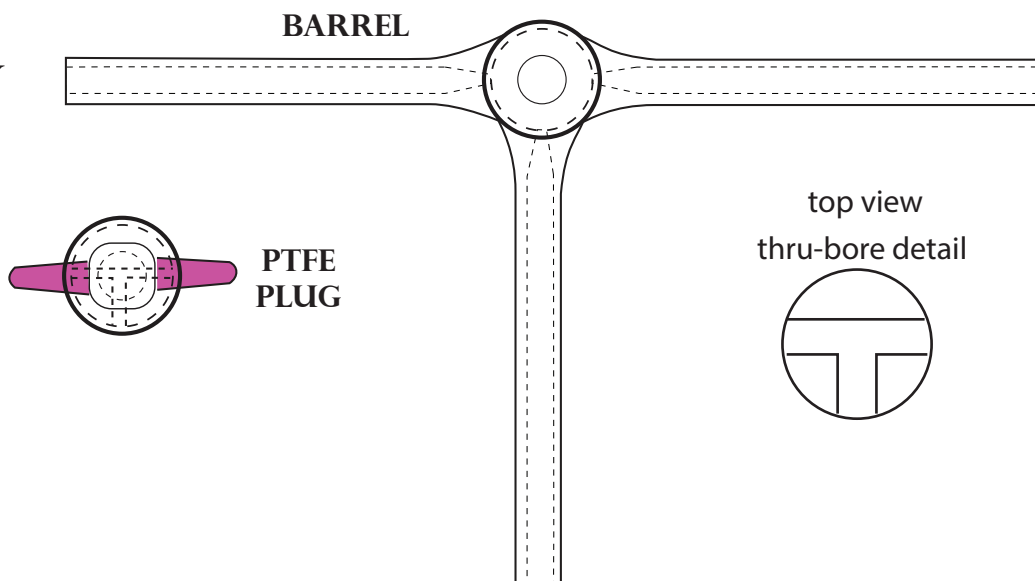

A stopcock consists of 2 parts: a PTFE plug that sits inside the glass barrel.

A PTFE washer, rubber O-ring and nut thread onto the plug to secure it inside the barrel.

The stopcock size is designated by a single number, which is the diameter (in milimeters) of the hole (or holes) going through the plug,

PTFE stopcocks have a 1:5 taper. 2 milimeters of plug diameter for every 10mm of its length

**Typical PTFE Stopcock Sizes: 2 mm, 4 mm, 6 mm, 8 mm, 10 mm**

PTFE stopcock barrels have a smooth clear finish and do not require grease.

# STOPCOCK, T - BORE WITH SOLID GROUND GLASS PLUG

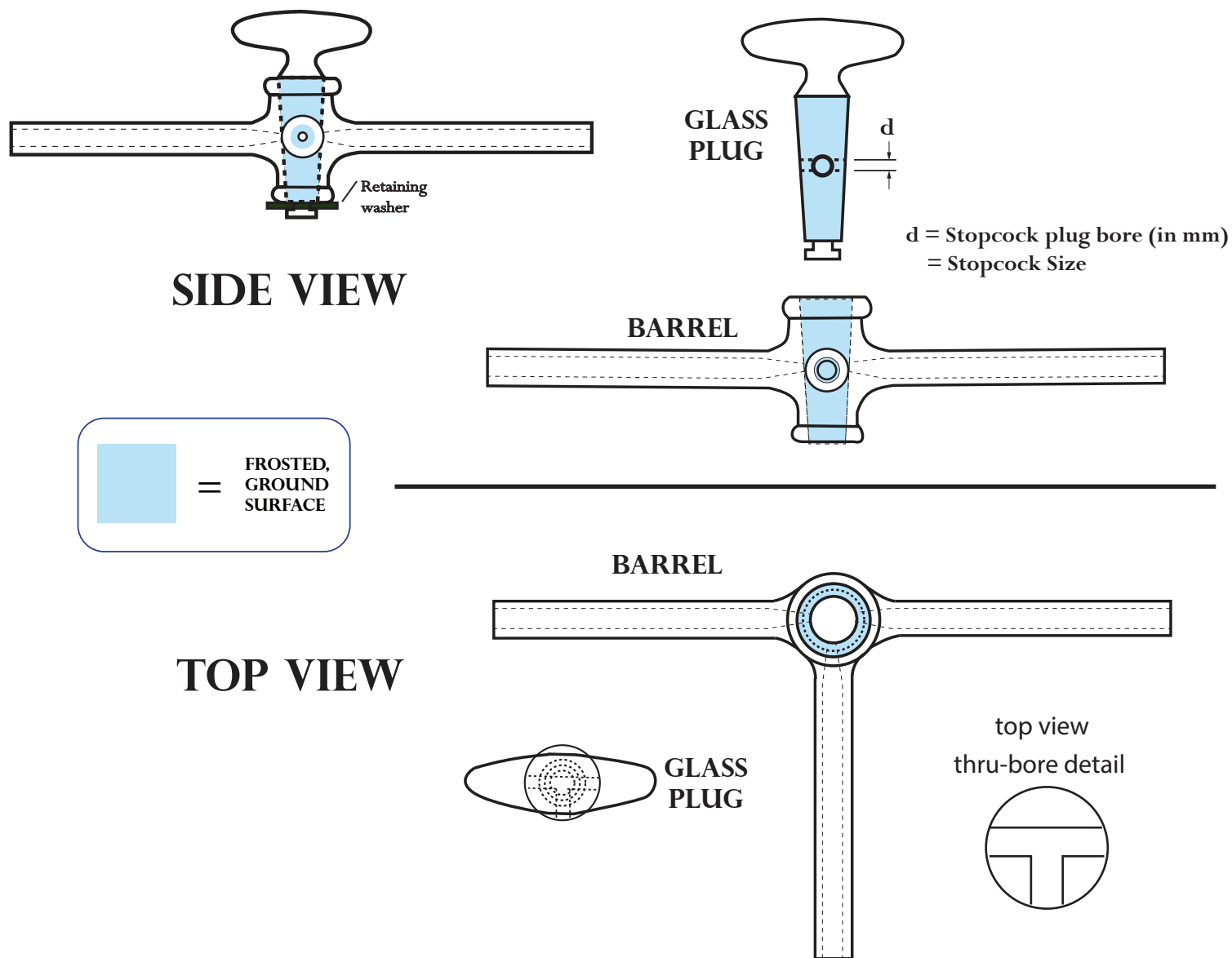

A ground glass stopcock consists of 2 parts: a glass plug that sits inside the barrel. The 2 parts are ground to achieve mating surfaces. A metal retaining clip or rubber washer on the bottom of the plug holds it fast in the barrel.

The stopcock size is designated by a single number, which is the diameter (in millimeters) of the hole (or holes) going through the plug.

Ground glass stopcocks have a 1:10 taper. 1 millimeter of plug diameter for every 10mm of length.

**Typical Ground Glass Stopcock Sizes: 2 mm, 4 mm, 6 mm, 8 mm, 10 mm**

Ground glass surfaces require grease to prevent sticking. Use a grease such as Apiezon brand.

# STOPCOCK, DOUBLE OBLIQUE WITH SOLID GROUND GLASS PLUG

## SIDE VIEW

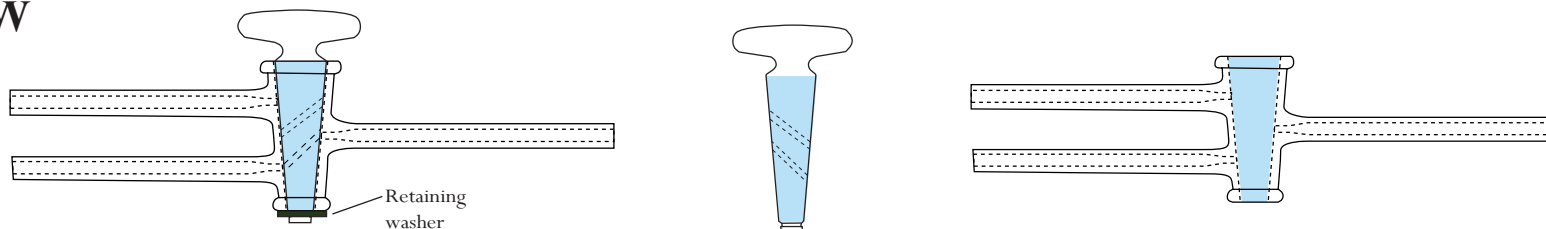

**STOPCOCK = PLUG + BARREL**

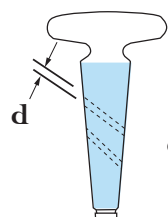

$d$  = Stopcock plug bore (in mm)  
= Stopcock Size

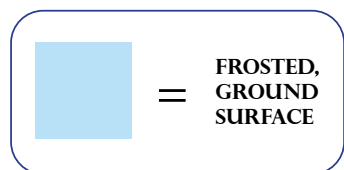

## TOP VIEW

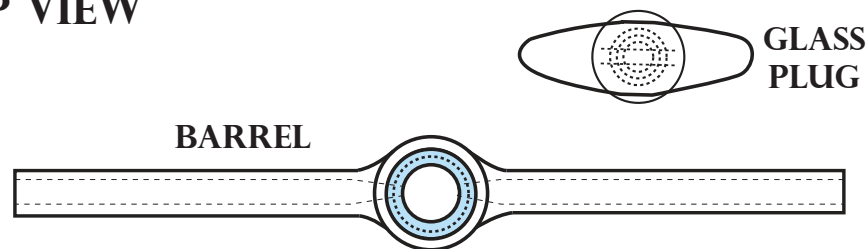

A ground glass stopcock consists of 2 parts: a glass plug that sits inside the barrel. The 2 parts are ground to achieve mating surfaces. A metal retaining clip or rubber washer on the bottom of the plug holds it fast in the barrel.

The stopcock size is designated by a single number, which is the diameter (in millimeters) of the hole (or holes) going through the plug.

**Typical Ground Glass Stopcock Sizes: 2 mm, v4 mm, 6 mm, 8 mm, 10 mm**

Ground glass surfaces require grease to prevent sticking. Use a grease such as Apiezon.

Ground glass stopcocks have a 1:10 taper. 1 millimeters of plug diameter for every 10mm of .ts length.

Ground glass stopcocks are manufactured in accordance to **ASTM standard E675-02**.

# DOUBLE OBLIQUE STOPCOCK OPERATION

.A.

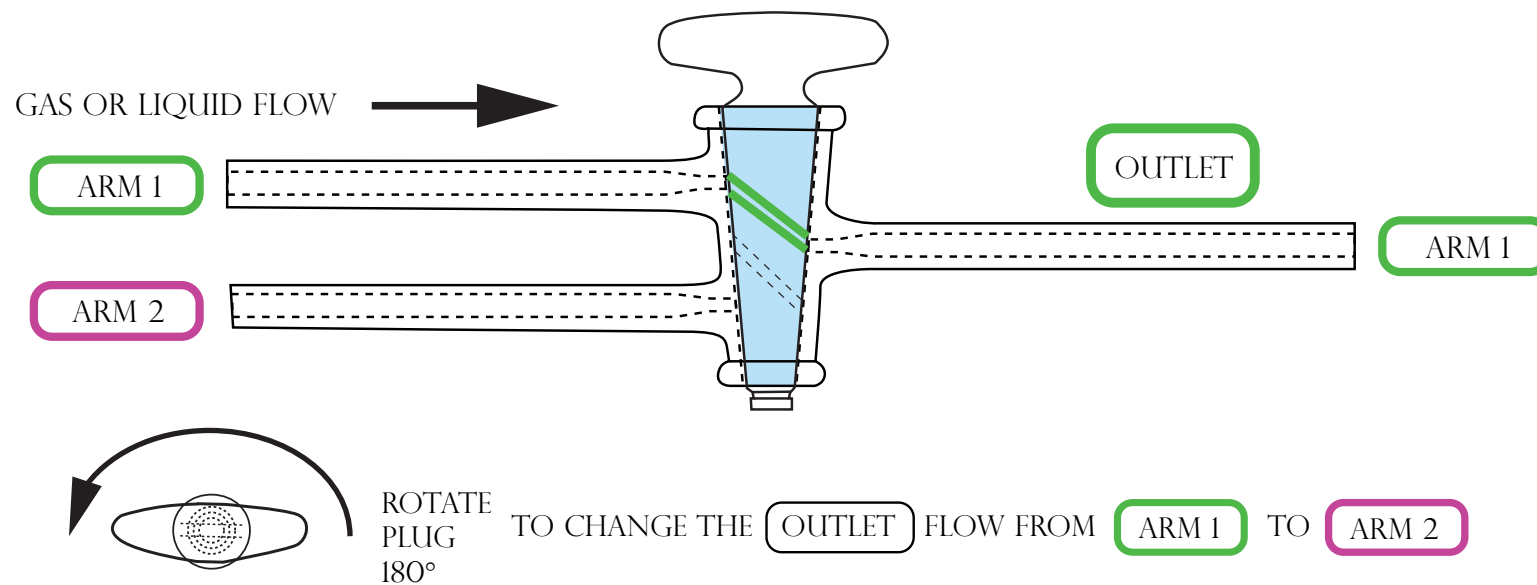

.B.

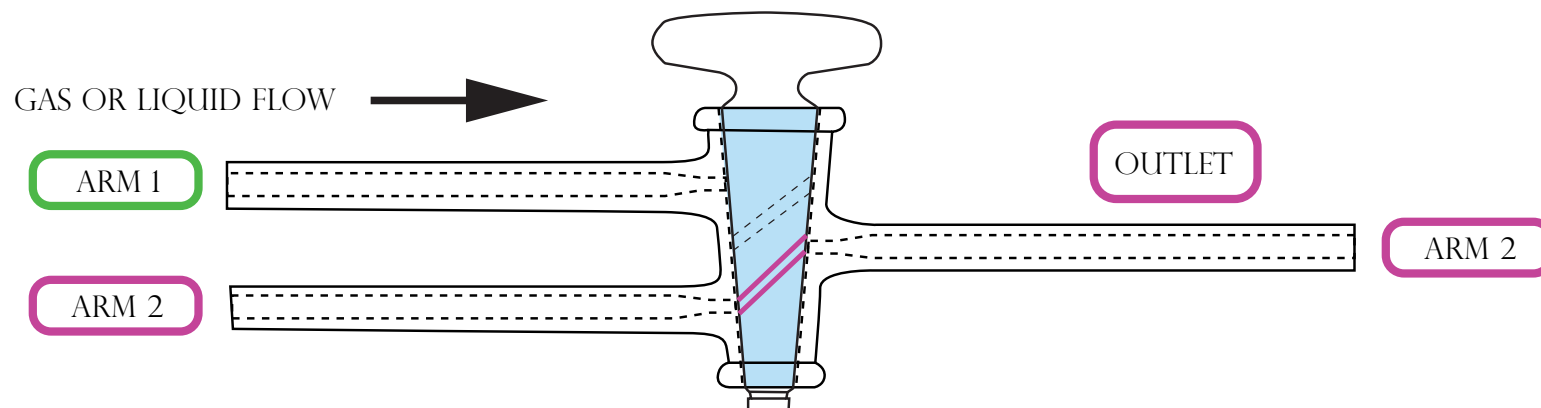

# STOPCOCK, STRAIGHT BORE WITH SOLID PTFE / TEFLON PLUG

---

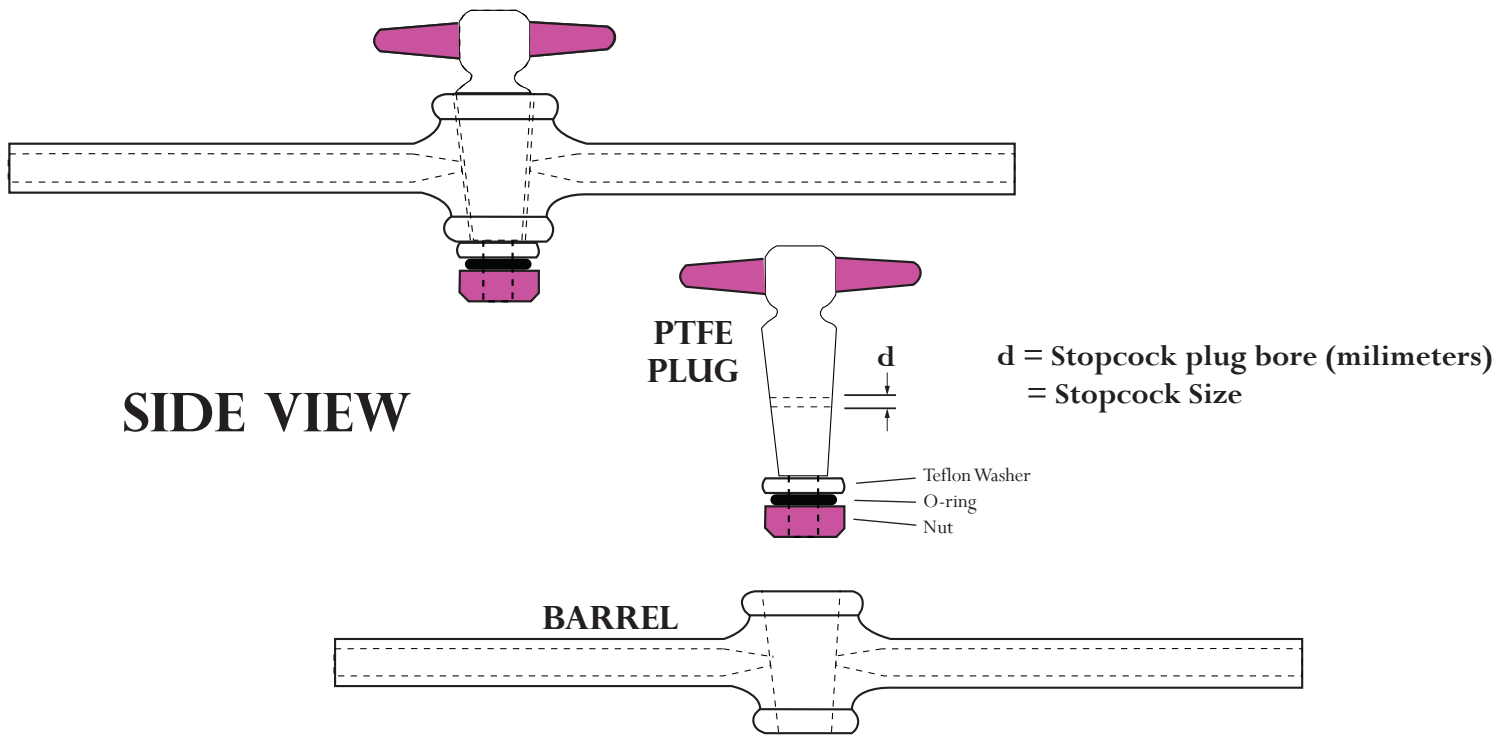

---

## TOP VIEW

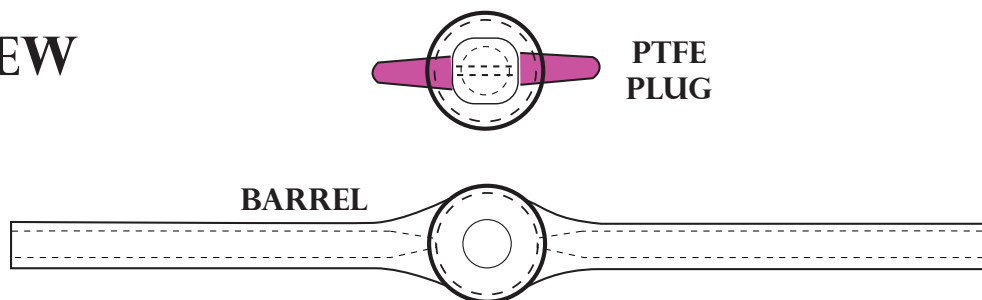

---

A stopcock consists of 2 parts: a PTFE plug that sits inside the glass barrel.

A PTFE washer, rubber O-ring and nut thread onto the plug to secure it inside the barrel.

The stopcock size is designated by a single number, which is the diameter (in millimeters) of the hole (or holes) going through the plug,

PTFE stopcocks have a 1:5 taper. 2 millimeters of plug diameter for every 10mm of its length

**Typical PTFE Stopcock Sizes: 2 mm, 4 mm, 6 mm, 8 mm, 10 mm**

PTFE stopcock barrels have a smooth clear finish and do not require grease.

PTFE stopcocks are manufactured in accordance to **ASTM standard E911-98**.

# STOPCOCK, STRAIGHT BORE WITH SOLID GROUND GLASS PLUG

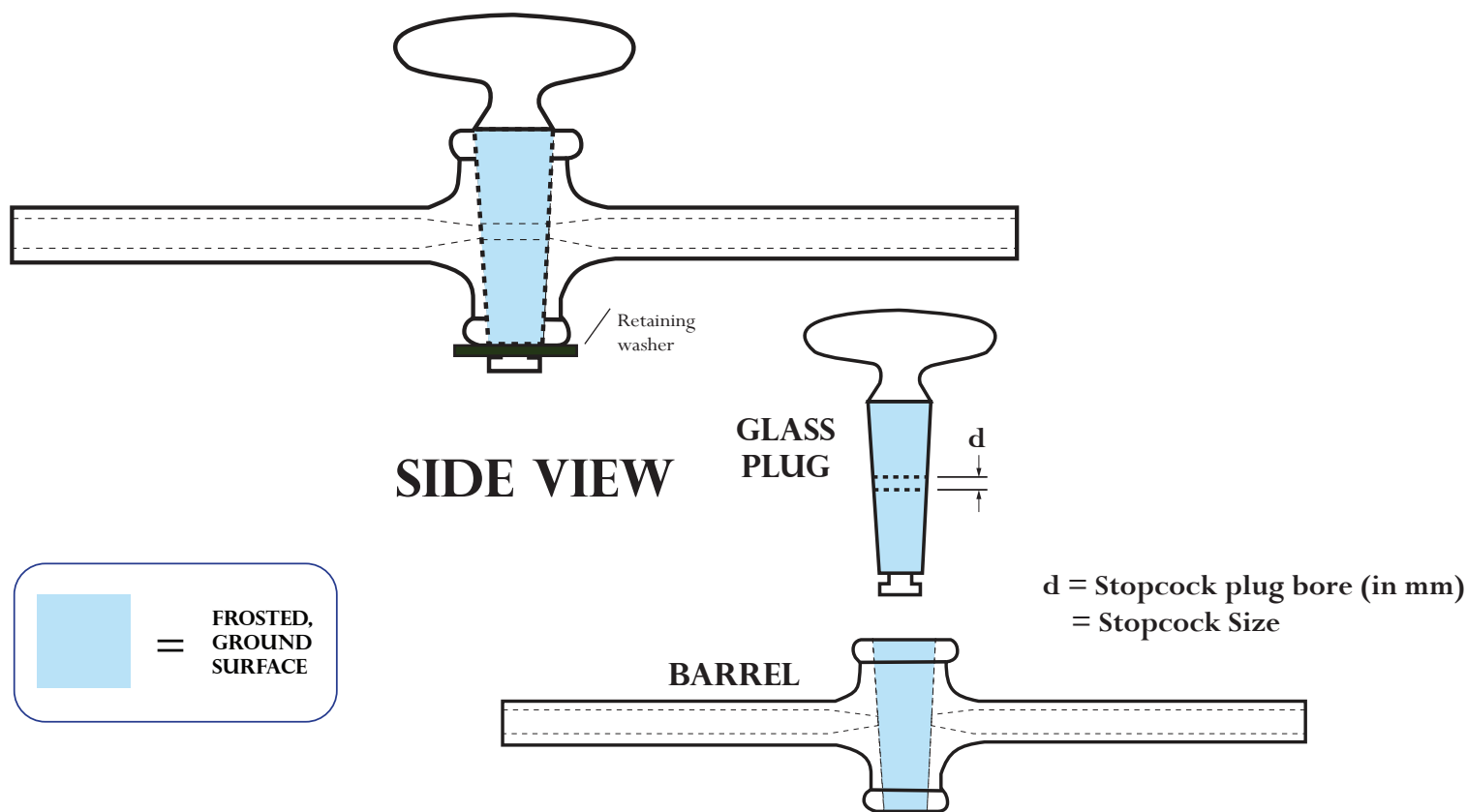

A ground glass stopcock consists of 2 parts: a glass plug that sits inside the barrel. The 2 parts are ground to achieve mating surfaces. A metal retaining clip or rubber washer on the bottom of the plug holds it fast in the barrel.

The stopcock size is designated by a single number, which is the diameter (in millimeters) of the hole (or holes) going through the plug.

Ground glass stopcocks have a 1:10 taper. 1 millimeter of plug diameter for every 10mm of length.

**Typical Ground Glass Stopcock Sizes: 2 mm, 4 mm, 6 mm, 8 mm, 10 mm**

Ground glass surfaces require grease to prevent sticking. Use a grease such as Apiezon brand.

Ground glass stopcocks are manufactured in accordance to **ASTM standard E675-02**.

# GLASS VALVE

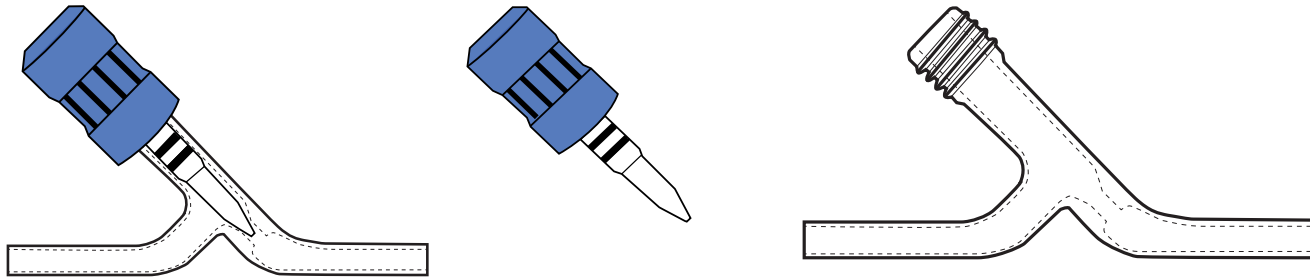

**VALVE = PLUG + BARREL**

## HOW IS THE VALVE SIZED?

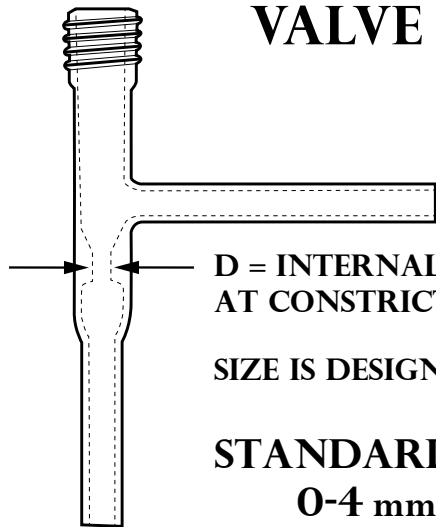

**D = INTERNAL HOLE DIAMETER  
AT CONSTRICTION (IN MILLIMETERS)**

**SIZE IS DESIGNATED AS 0 - \*D\***

**STANDARD VALVE SIZES:**

- 0-4 mm**
- 0-8 mm**
- 0-12 mm**

## TYPICAL VALVE TYPES

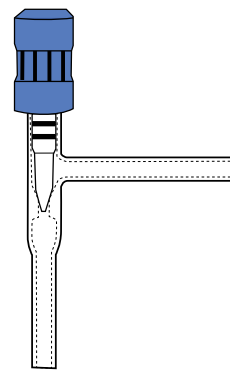

**90°**

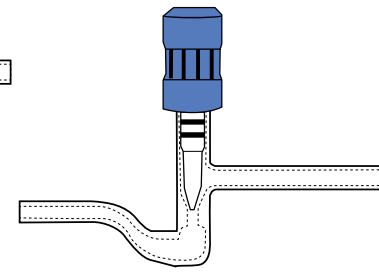

**180°**

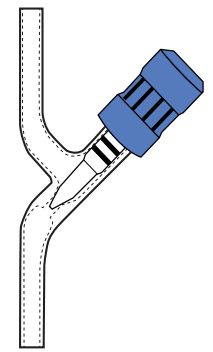

**LOW HOLD-UP**

# PLUG OPTIONS

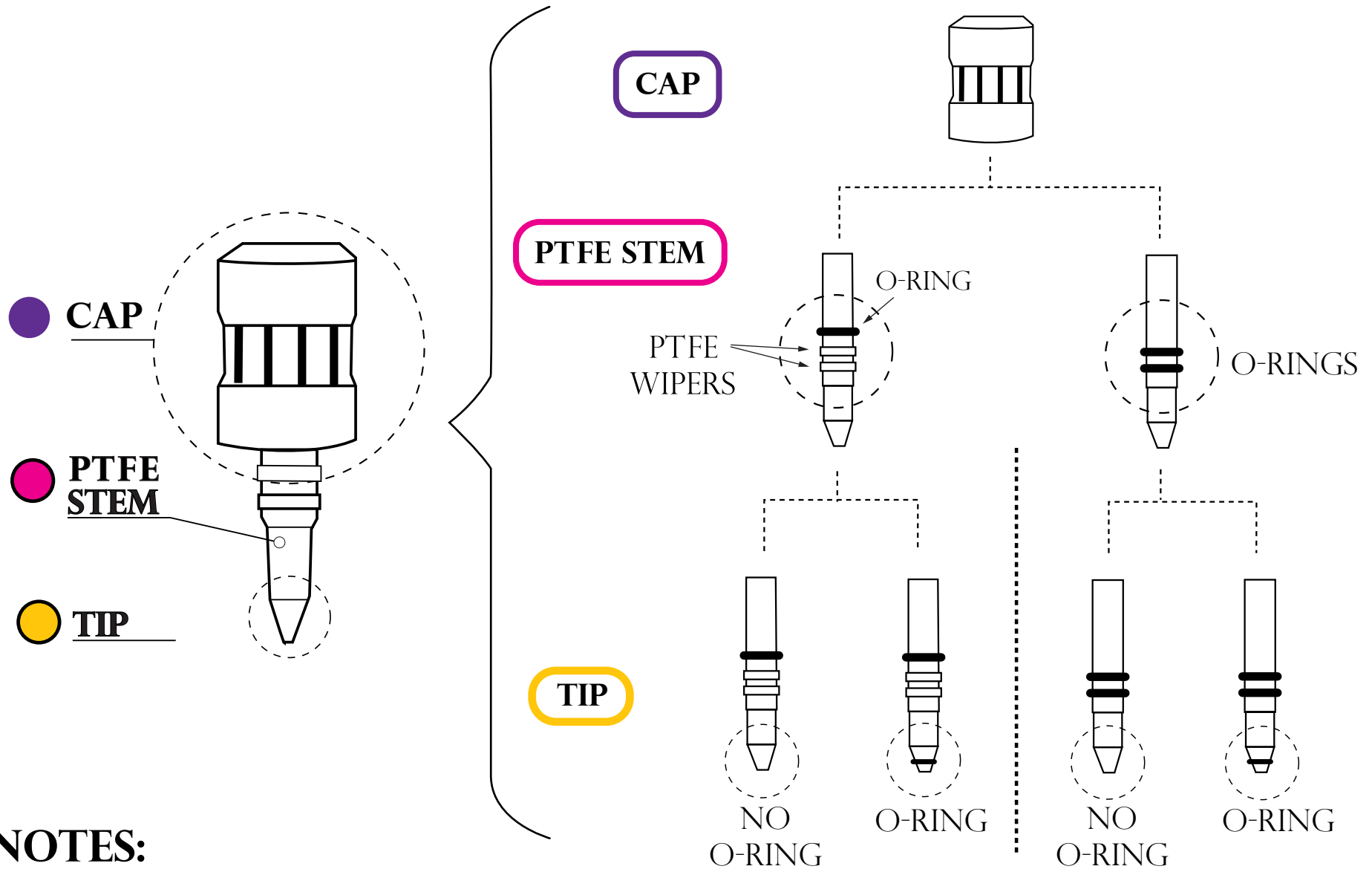

## NOTES:

O-RINGS NEED TO BE REPLACED.

O-RINGS ON THE TIP ARE RECOMMENDED FOR CRYOGENIC APPLICATIONS WHERE THE O-RING IS BETTER ABLE TO ABSORB PTFE SHRINKAGE IN THE PLUG STEM, AND STILL MAINTAIN A GOOD SEAL.

# BARREL THREAD TYPES

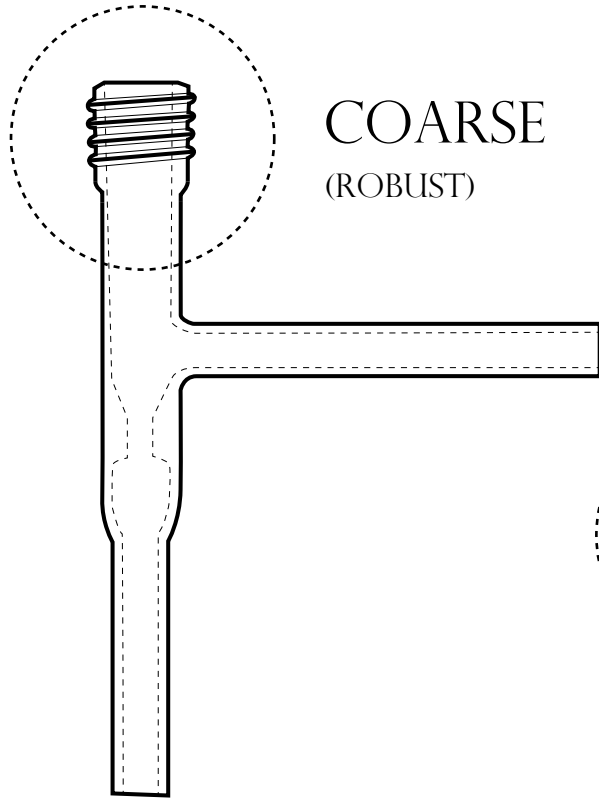

COARSE  
(ROBUST)

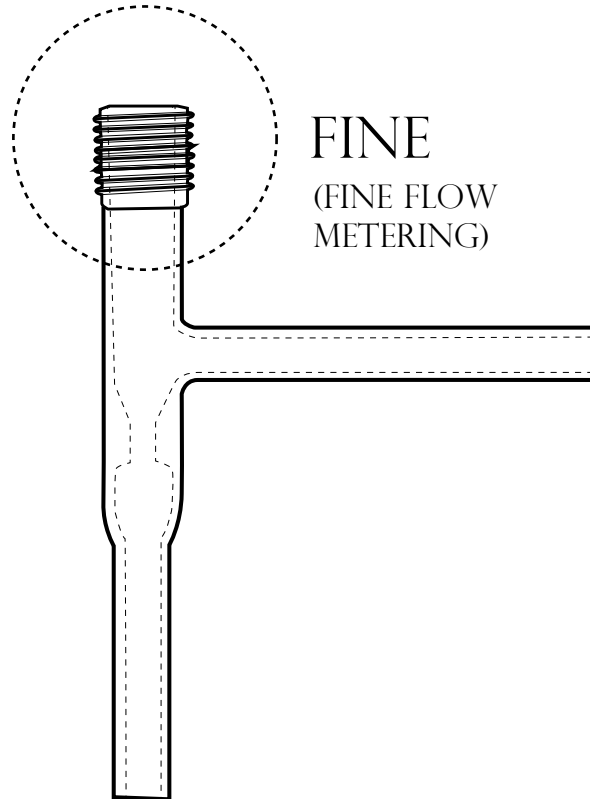

FINE  
(FINE FLOW  
METERING)

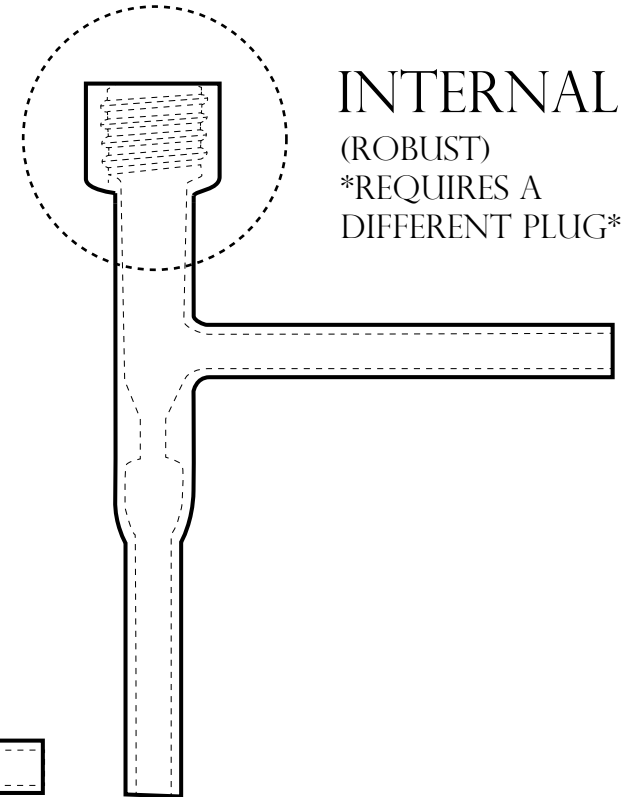

INTERNAL  
(ROBUST)  
\*REQUIRES A  
DIFFERENT PLUG\*

# GROUND GLASS CHECK VALVE

---

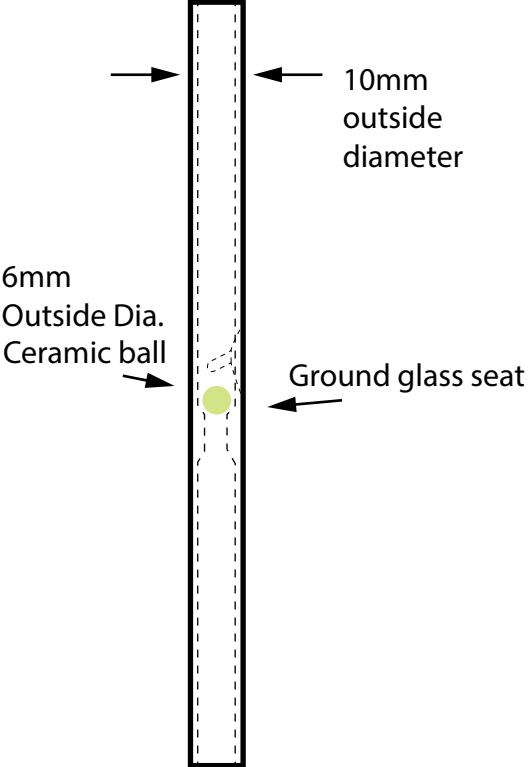

Check valves can be added to prevent the back-flow of a liquid.